

Handicare 2000 | QUICK REFERENCE GUIDE

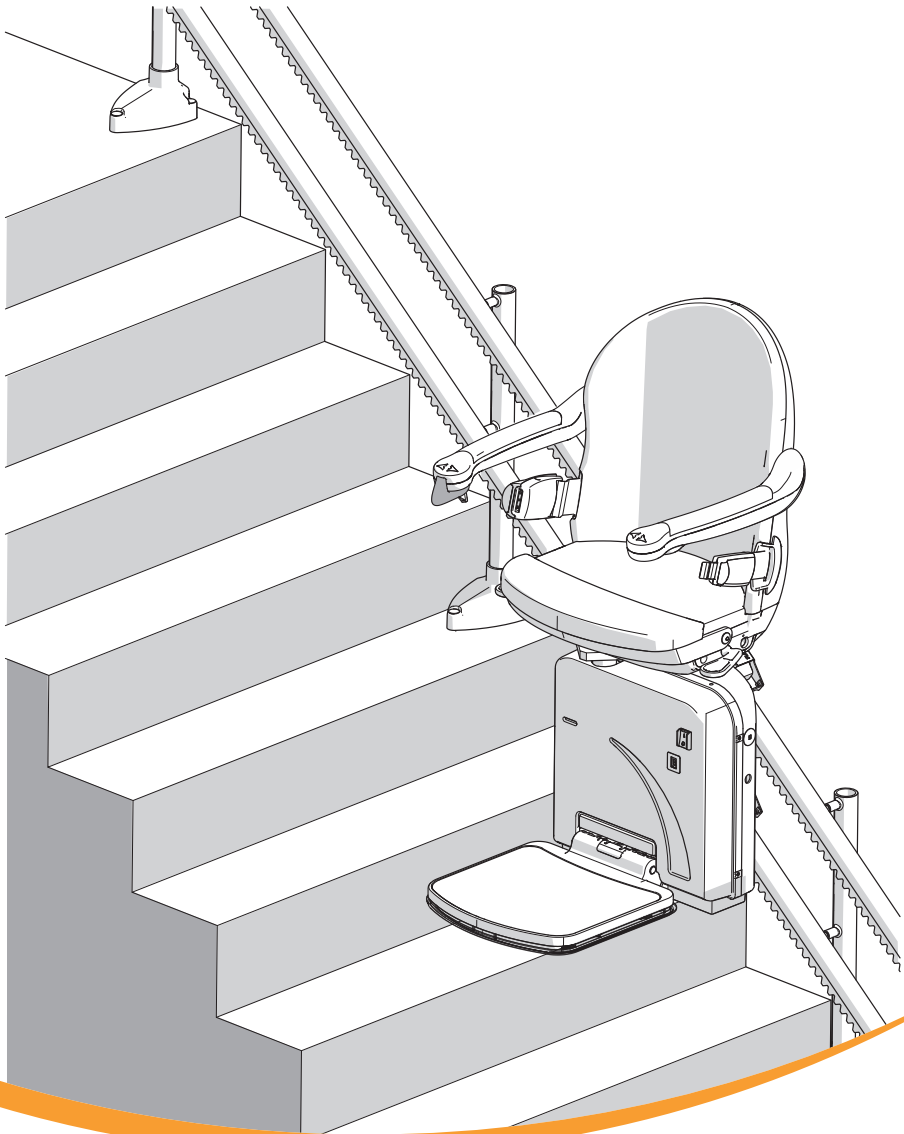

VERSION 2.1

Contents

1. Introduction	2
2. Display codes	3
3. References	5
4. Glossary	6
5. Testing	10
6. Display	11
7. Toggle	11
8. The remotes	11
9. Safety edges	12
10. The batteries	13
11. Charging power supply	14
12. Boards	15
13. Options	16
14. Rescuing the user	18
15. Faults	19

1. Introduction

This guide is intended for use as a general reference by engineers repairing faults on the Handicare 2000. The guide is structured as follows: the first chapter provides general information about the Handicare 2000, including how the Handicare 2000 should be tested, where the components are located and how they react to certain situations. The subsequent chapters deal with repairing faults. Flow charts are used in some cases, where step-by-step choices have to be made in order to find the cause of the fault.

There is room for improvement in every guide. If you have any tips or suggestions, please let us know so that we can incorporate them. We wish you the best of luck with your tasks and hope that this guide will be of assistance.

2. Display codes

Left hand

Code	Meaning	Page
None	Power off	24
–	Charging, joystick failure	23,26
0	General safety line	22
1	Requires charge	31
2	Off charge	31
3	Top track limit activated	27
4	Top safety edge activated	29
5	Bottom track limit activated	28
6	Bottom safety edge activated	30
7	Low battery voltage	31
8	UP travel direction	21
9	DOWN travel direction	21
A	Hinge open	35
b	Toggle switch active at power up	21
C	IR address fail	32
d	Relay not open	20
E	Relay not closed	20
F	Brake semi-conductor failed	21
G	Brake not connected	20
H	Relay not open (pre-delay)	20
J	Hinge interlock switch fault	34
L	Current limit exceeded	20
n	Lift driving at half speed	38
o	Default Eprom	21
r	Power supply fault during charging	31
U	Power supply fault when battery on float	31
y	Main board hardware fault	21
.ll.	Overcurrent	20

2. Display codes

Right hand

Code	Meaning	Page
None	Power off	24
–	Charging, joystick failure	23,26
0	General safety line activated	22
1	Requires charge	31
2	Off charge	31
3	Bottom track limit activated	27
4	Bottom safety edge activated	29
5	Top track limit activated	28
6	Top safety edge activated	30
7	Low battery voltage	31
8	UP travel direction	21
9	DOWN travel direction	21
A	Hinge open	35
b	Toggle switch active at power up	21
C	IR address fail	32
d	Relay not open	20
E	Relay not closed	20
F	Brake semi-conductor failed	21
G	Brake not connected	20
H	Relay not open (pre-delay)	20
J	Hinge interlock switch fault	34
L	Current limit exceeded	20
n	Lift driving at half speed	38
o	Default Eprom	21
r	Power supply fault during charging	31
U	Power supply fault when battery on float	31
y	Main board hardware fault	21
.ll.	Overcurrent	20

3. References

	Page
The general safetyline	22
The direction safetylines	29,30
The end limit switch	22,27,28,35
The batteries	24,31,34
The charger	31,35
The tractionmotor	21
The brake	21
The display	24
The on/off switch	24
The toggle	23,26
The armrestswitches	23,26
The hinge	33,34,35
The remotes	32
The infrared receiver	24,32
The fuse	24
The powered swivel	36
The powered footrest	37
The thermal fuse	24,32

4. Glossary

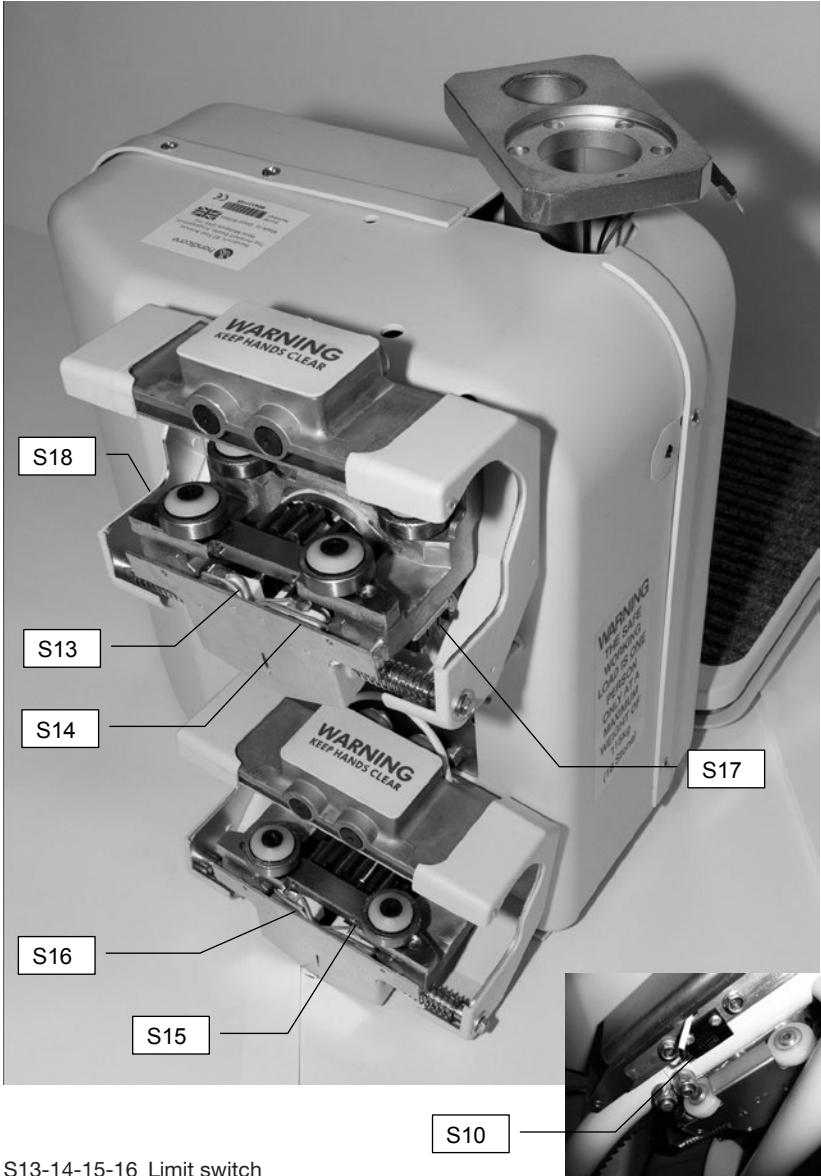

- S13-14-15-16 Limit switch
- S 17-18 Final limit switch
- S10 Speed switch (lower trunnion)
- S22 Hinge enable switch (top trunnion) not visible

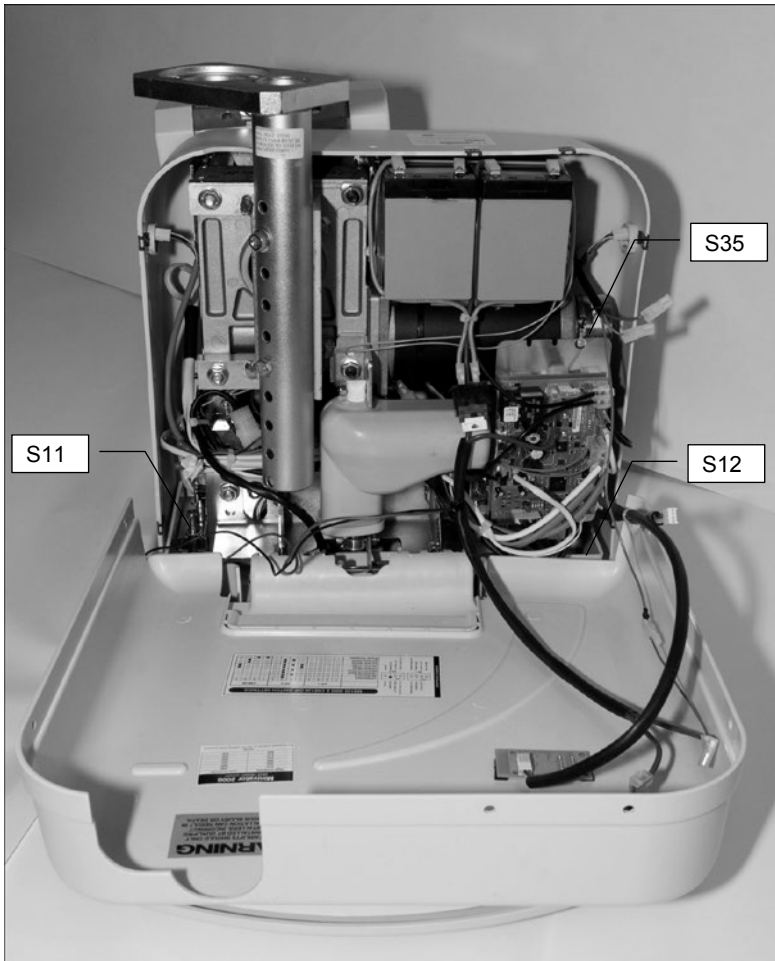

S11-12 Front chassis edge switch
 S35 Handwinderswitch
 Contact charging (lower trunnion)
 Contact communication hinge (upper trunnion)

Safety brake
 S19,S20 Overspeed governor switch
 Infrared receiver
 5-Amp-fuse/30-Amp-fuse
 Main board P1
 Motor
 Brake

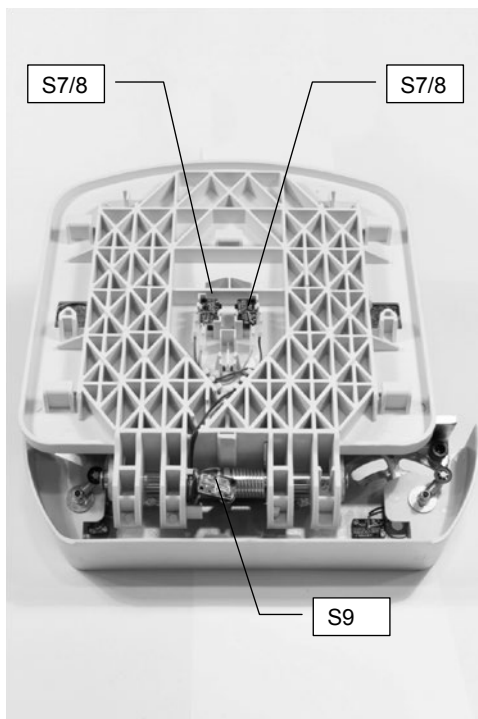

S7 Footrestswitch
 S8 Footrestswitch
 S9 Footrestswitch

Powered swivel

- Motor
- S25 Seat swivel switch
- Board P3
- S34 Emergency stop switch



Display
 S21 Mainswitch

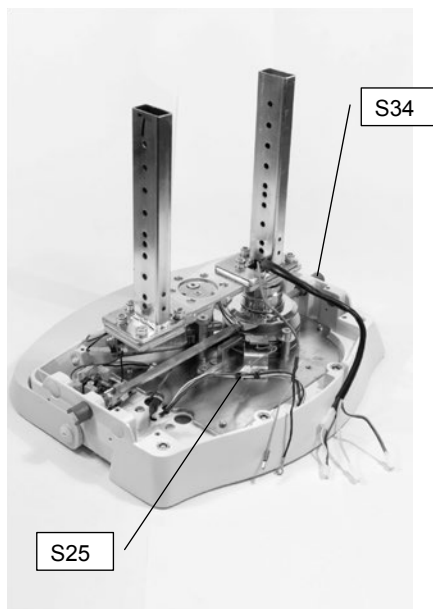

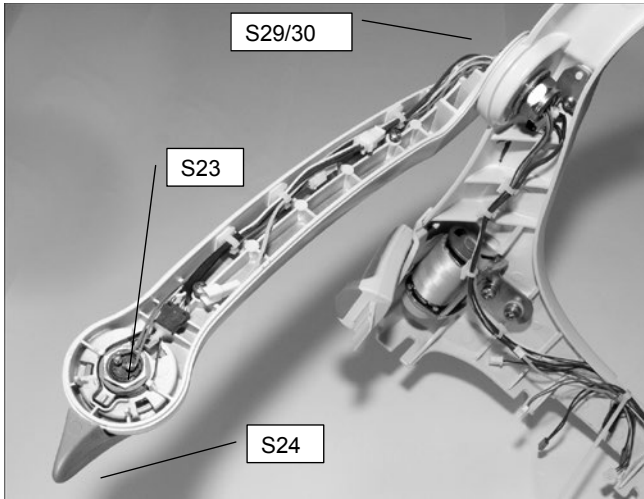

S24 Toggle
 S23 Keyswitch
 S29 – S30 Armrestswitches

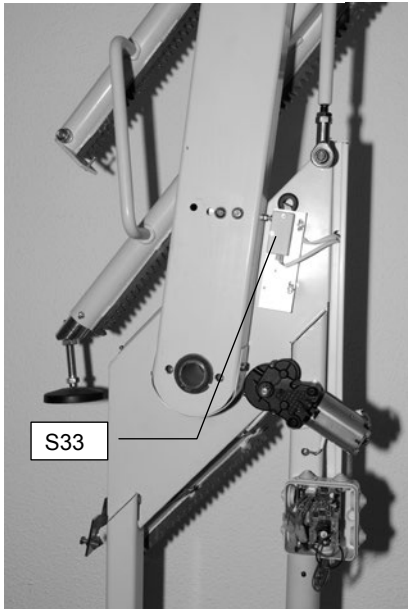

S31 Foldable hinge contact
 S32 Foldable hinge contact
 S33 Foldable hinge contact
 Motor
 Board P4

5. Testing

The circuits should be tested as follows:

- Use the electrical diagram to see which circuit you need to test
- Disconnect the Handicare 2000 from the power supply
- Connect the molex testing link to the pcb
- Ensure looms are removed from pcb before carrying out continuity testing
- Set the multimeter to the “beep” or resistance or voltage test mode
- Check that you are testing between the correct connector pins/ numbers.
- No “beep” or resistance means that the circuit being tested is not complete.
- Voltages can be find on the electrical scheme

If there is a short circuit with the frame, hold one of the measuring pins against the unit’s ground pin of the seat and push the other measuring pins into the top of the molex testing link.

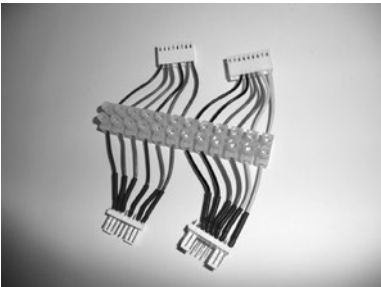

Molex testing link

6. Display

On the lift is a display which shows a diagnostic code to help you to locate the cause of the breakdown. The codes can be found on page 4/5 and in the user- and installation manual.

7. The toggle

The lift is operated by the toggle on the armrest. The toggle as well as the key switch or the button for the powered footrest raiser can be swapped from right to left on side.

The lift will not ride when the armrests are in the folded position. It does



however operate on the remotes. During the ride the diagnostic display show “8” or “9”.

An installation toggle loom can be used to ride the power pack without chair. (art. Nr.181001.50083).

In case of a public building when the key switch should switch off the toggle but the remotes should stay operational, the key switch needs to be transferred from the safety line to the control line.

8. The remotes

The remotes function on infrared. On the backside is a dipswitch for setting a different code.

The lower button is a special button for parking the lift. On the backside is a red, orange or green cover. Green means the remote functions on

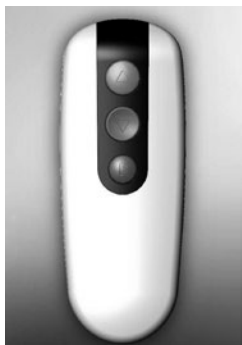

radiofrequency (2,4 Ghz), red means the remote functions on infrared. Orange means the remote functions on 868 Mhz.

Under this cover you can find a dipswitch to set a different canal.

The infrared remotes work out of the box. If they don't, they can be linked as follows: Press and hold the red button on the board P1. A yellow light will illuminate on the board. Press any button on the handset and the light will go out.

9. The safety edges

Two direction-sensitive safety edges and one general safety edge have been included in the Handicare 2000.

The direction-sensitive safety edges

The direction-sensitive safety edge prevents the lift from moving further in the direction that is blocked.

However, the Handicare 2000 can still be moved in the opposite direction to remove the block.

The diagnostic code shows "4" or "6"

The following switches have been included in the direction-sensitive safety edge:

- Footrest switches
- Detection switches for the power pack

The handing of the safety edges is when sitting on the lift.

The general safety edges

The general safety edge prevents the lift from moving further in both directions.

The diagnostic code shows “0” when the toggle is moved in either direction if the safety edge is obstructed.

The following switches have been included in the general safety edge:

- Seat swivel switch
- Overspeed governor switch
- Key-operated switch
- Final limit switch
- The emergency stop
- The handwinder switch

10. The batteries



Two 12V 7,2 Ah maintenance-free lead-acid batteries are used. They have an expected life span of three years.

If the output voltage of one of the batteries is at least 5V less than that of the other, it can be assumed the battery is faulty. If the voltage between the batteries varies, there is something wrong with them.

Guarantee

No guarantee is provided for the batteries. However, we do ask that you report any complaints to us, stating the identification number on the battery.

11. Charging power supply



The battery charger is suitable for an input voltage of between 100V and 240V. The output voltage is 33 V=. The charging current is 1 A.

There are different diagnostic codes if the lift requires charge

Code 1 and 7: When the battery voltage is very low (maybe down to 10% capacity left in batteries), this fault code will appear. When the lift docks on to charge contacts, the lift will not drive off the contacts. 1 will flash. Lift will only drive off if battery voltage has recovered approximately three quarter capacity. Another way of driving off the contacts is if lift is powered “off” then back “on” but as soon as lift docks on contacts, process will repeat again. This fault code is linked to fault code 7 but the code 7 is not usually seen as code 1 takes priority.

Code r: This fault will occur when the lift is charging. If the power supply is disconnected while the lift is charging, the r code will display. A fault with the 33V power supply where the power supply cannot supply current to charge the batteries will also show this code.

Code U: This fault occurs when the lift has fully charged the batteries and is in float mode. When the 33V power supply is disconnected, the U code will display.

Code E: This fault appears if the batteries are low. The main relay on the board is rated for 24VDC operation so the low voltage will give a false fault condition.

12. Boards

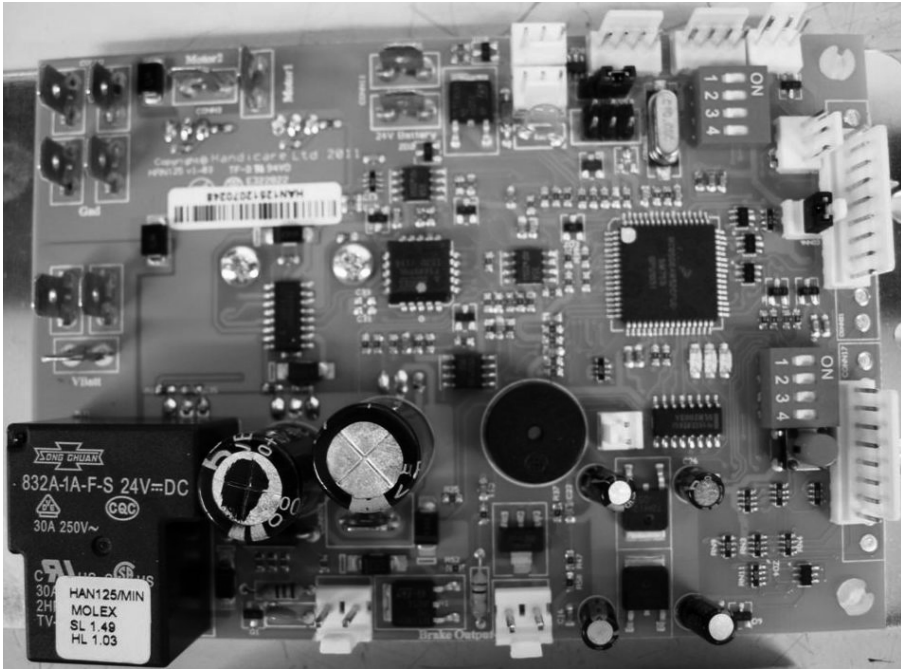

125 Mainboard P1

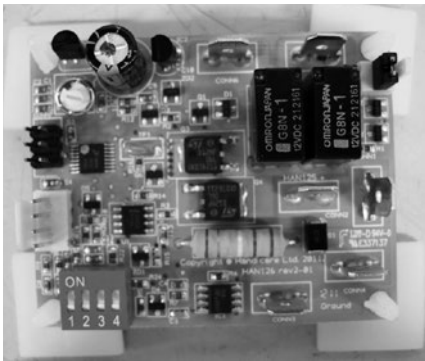

126 Powered swivel P3
126 Foldable hinge P4

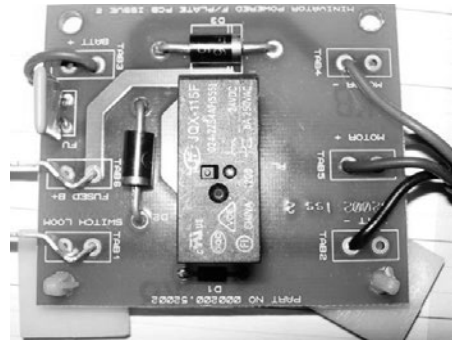

Powered footrest raiser P2

13. Options

The stairlift can be extended with extra powered options:

- Powered swivel chair
- Powered footrest raiser
- Foldable hinge

Logic

The grey communication loom provides a link between the MS125 pcb and the 126 pcb.

The 126 connection on the MS125 pcb output is between 8-12 volts. Each time a 126 pcb is connected, the reading will drop by approximately 0.8 volts as communication between the two pcb's is established.

The 126 pcb dip switch settings tell the MS125 pcb what powered option is connected. Each dip switch setting is looking for different parameters to determine when and where power should be applied to the attached motor.

When the parameters are met, the MS125 pcb passes the battery voltage through the communication loom to the 126 pcb. The 126 pcb then reduces the output to the correct voltage for the attached motor to power the option. Depending on which option is attached, voltage would be applied to the motor for a set time or until the motor has hit a stop, the 126 pcb has a stall current.

In case of a failure on the communication circuit, the lift runs, but the options don't function.

Powered swivel chair

The powered swivel chair swivels at the top and is operated from the toggle. The lift shall be on the upper end limit switch and the board

should detect the charge voltage. The powered swivel chair can be operated manually in case of emergency.

Powered footrest raiser

The powered footrest raiser is powered from a button under the armrest or from a switch between the 2 seat parts. The powered footrest can be activated all along the track.

The pcb used for the powered footrest raiser does not communicate with the main pcb. The safety and the limits are build into the footrest motor.

The foldable hinge

The foldable hinge is operated by the toggle. From the top of the stairs, the toggle is pushed in the down direction. The lift will drive down the track until it reaches the intermediate charge contacts. The lift will stop at this point. Keep the toggle pushed in the down direction. After a short pause the hinge will lower.

On the rail at the top and just above the foldable hinge are 2 contacts. The contact on the upper tube is for the communication and the contact on the lower tube is for the charging.

On the backside of the unit is a foldable hinge enable contact. This contact shall be activated by the ramp to enable the foldable hinge to move. At the same time the copper strip in the power pack shall have contact with the copper strip on the rail, so the lift “sees” 33V=. In case of a power down the foldable hinge will act on the foldable hinge enable contact only.

On the rail are 2 switches to control the end position of the hinge and to enable the lift to drive in case the hinge is completely (un) folded.

On the main board the dipswitch to enable foldable hinge shall be activated. And on the board in the electric box on the rail shall be activated. Consult the electric scheme for the right setting off the dipswitch.

14. Rescuing the user

Instructions for rescuing a user seated on a chair lift of the type Handicare 2000 that is still at the top of the stairs.

Check the status of the stairlift via the diagnostic display. Remove faults in the stair lift that could pose a danger to the user. For example, faults in the footrest safeguard, in the operation, detection strips or the chair position switch.

Never ride with the user on the lift when a safety measure is switched off.

If it is not possible to remove the fault without danger to the user, first release the user:

In such case ensure that you are positioned above the user and the chair lift at all times.

Move the user to safety by turning the chair in the direction of the stairs. Lock the chair in place. Unfasten the safety belt. The client may now step in the direction of the stairs and proceed to the floor above. Remove the fault; if necessary, you may ride the chair lift to the floor level using the manual hand wheel, for which please refer to the manual.

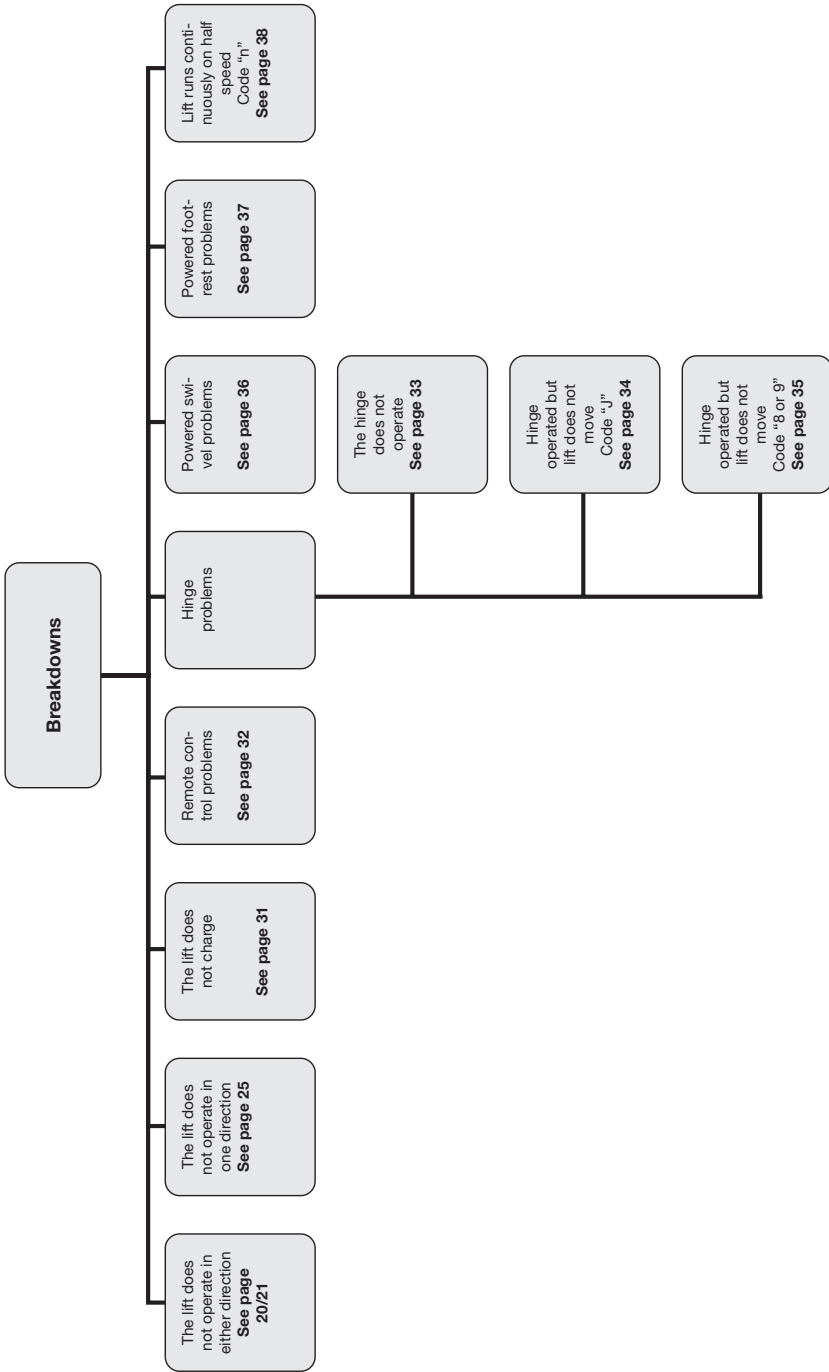

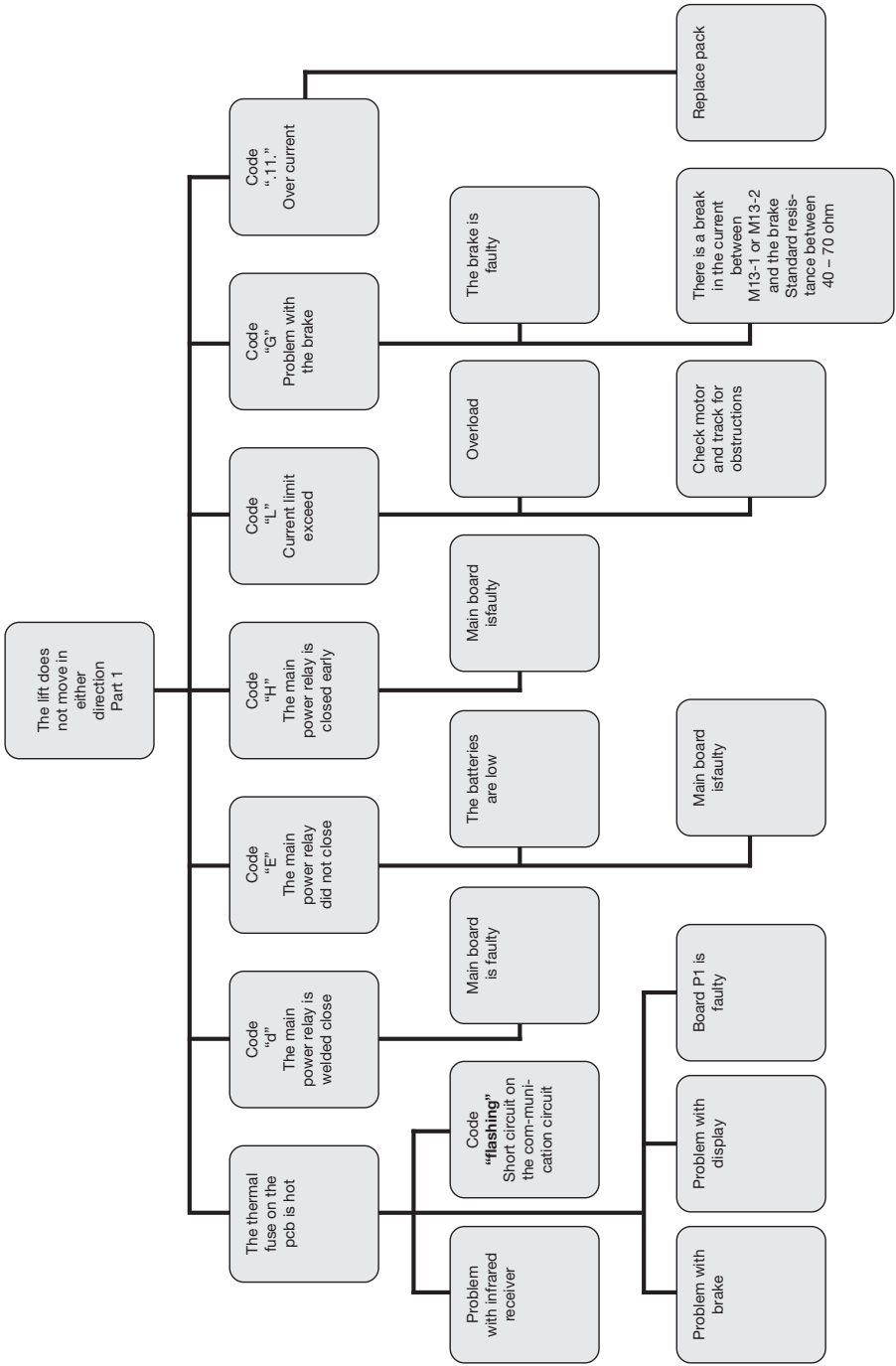

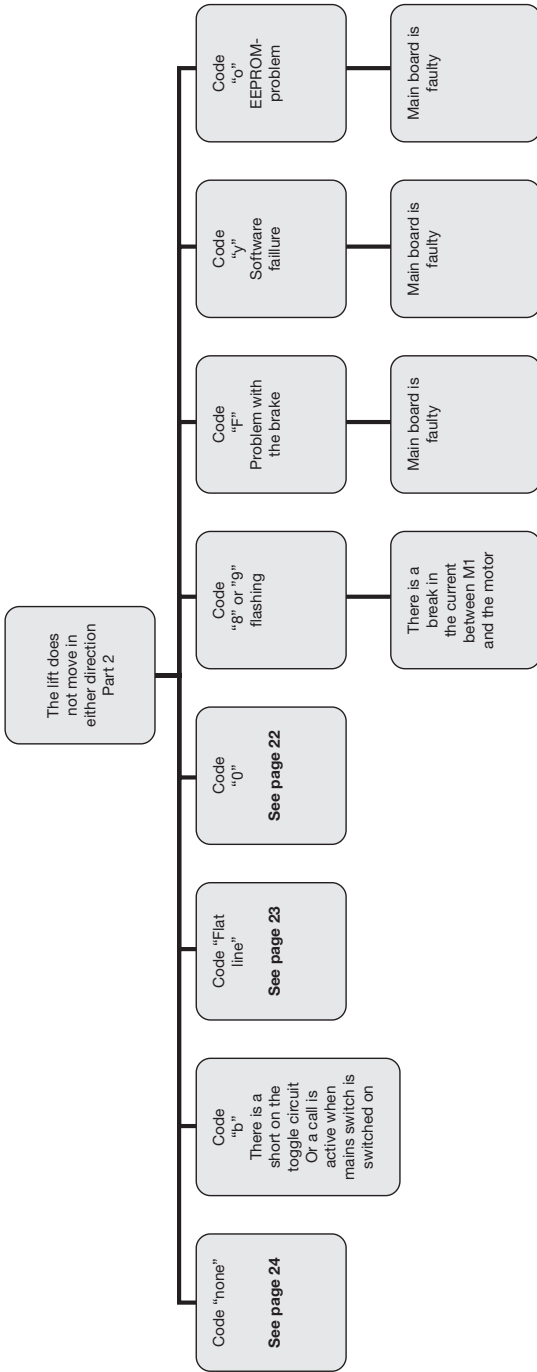

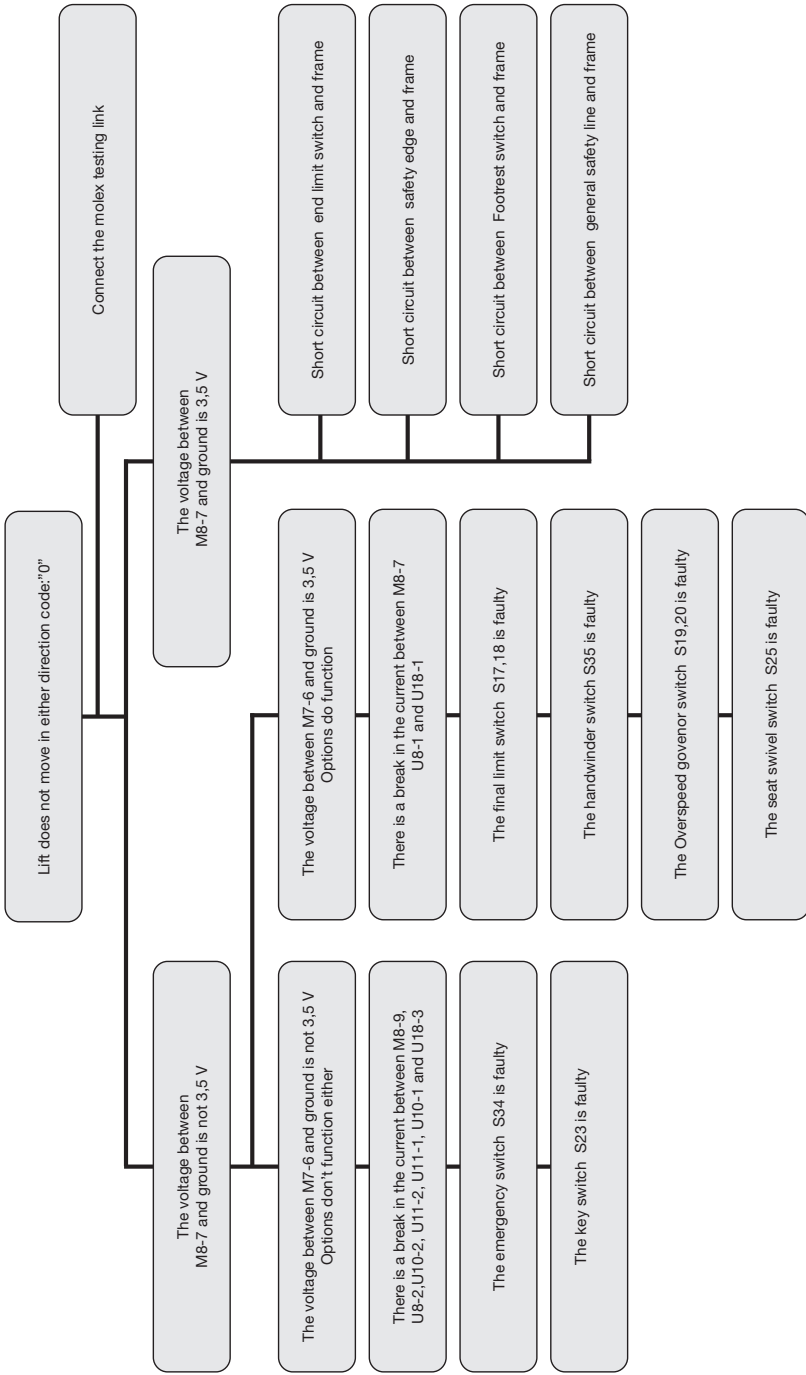

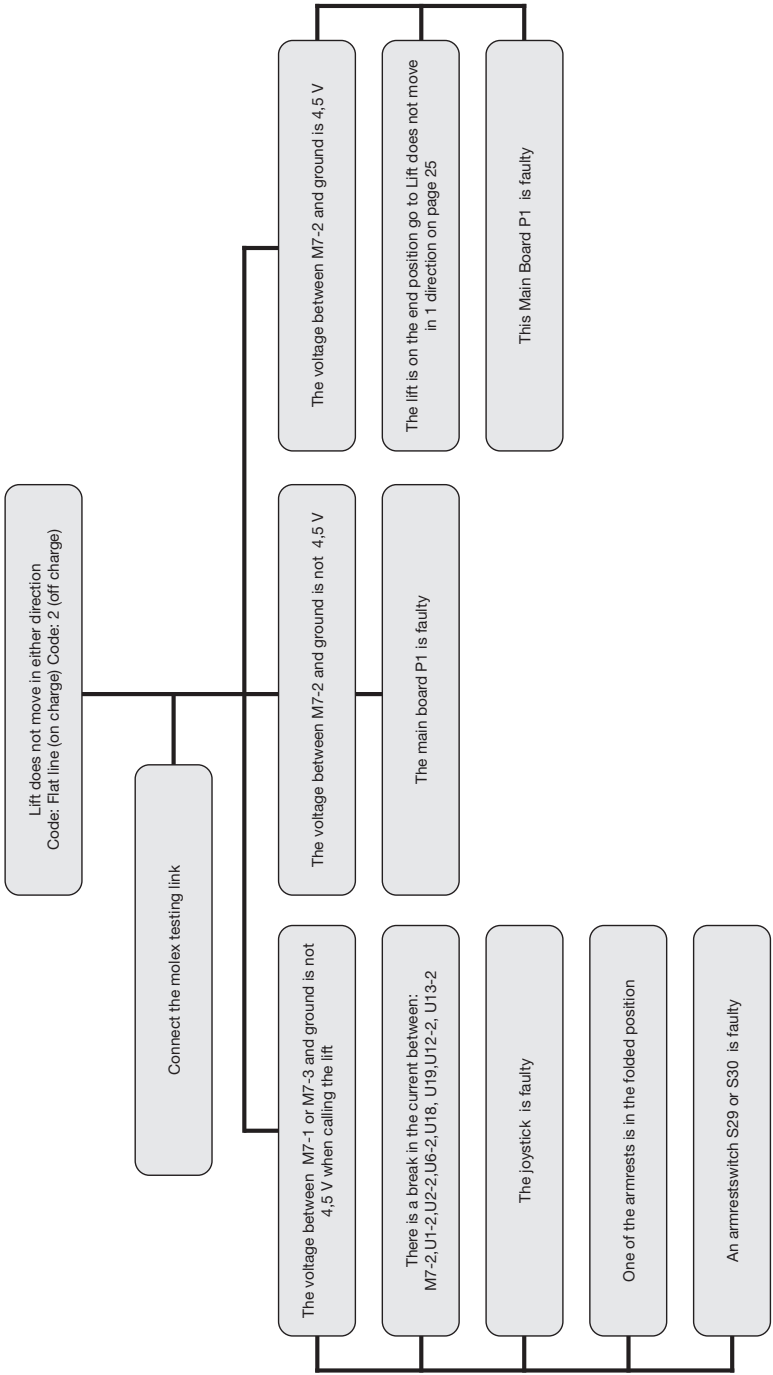

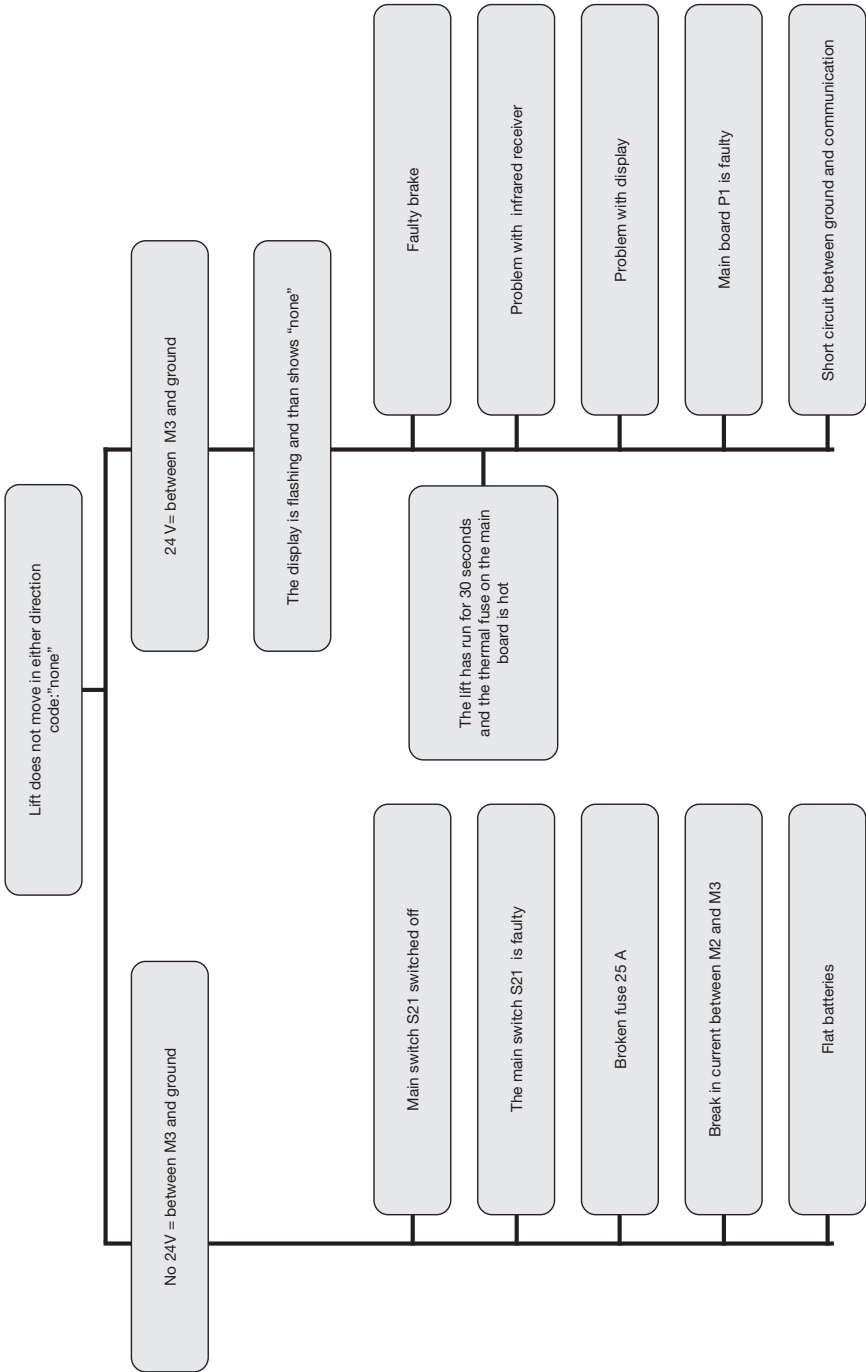

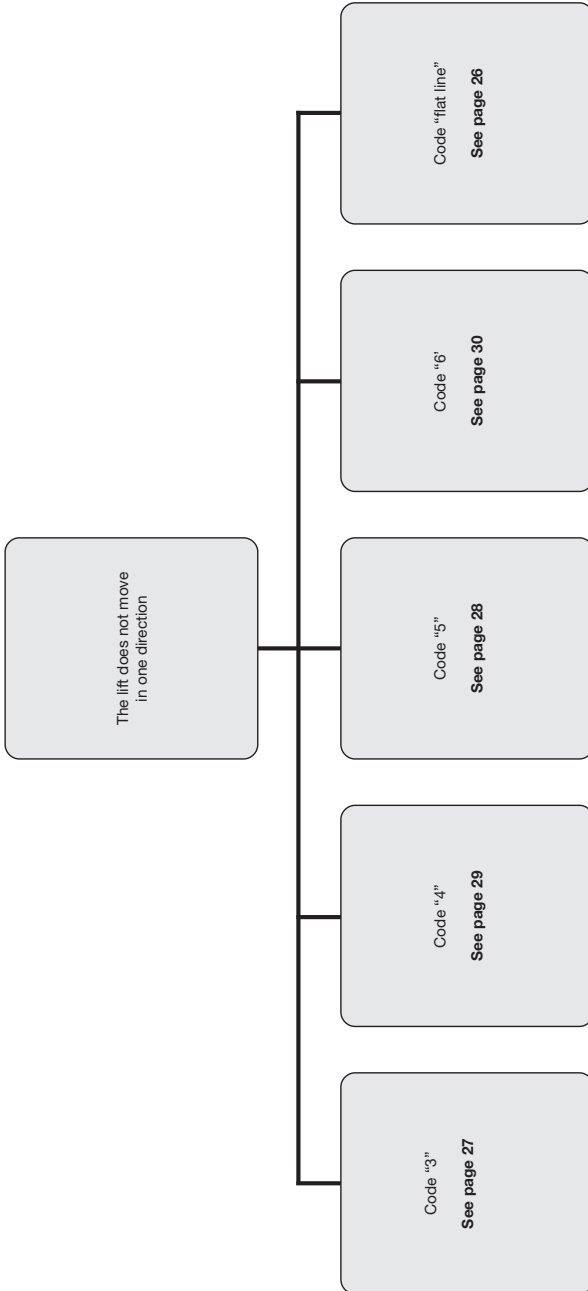

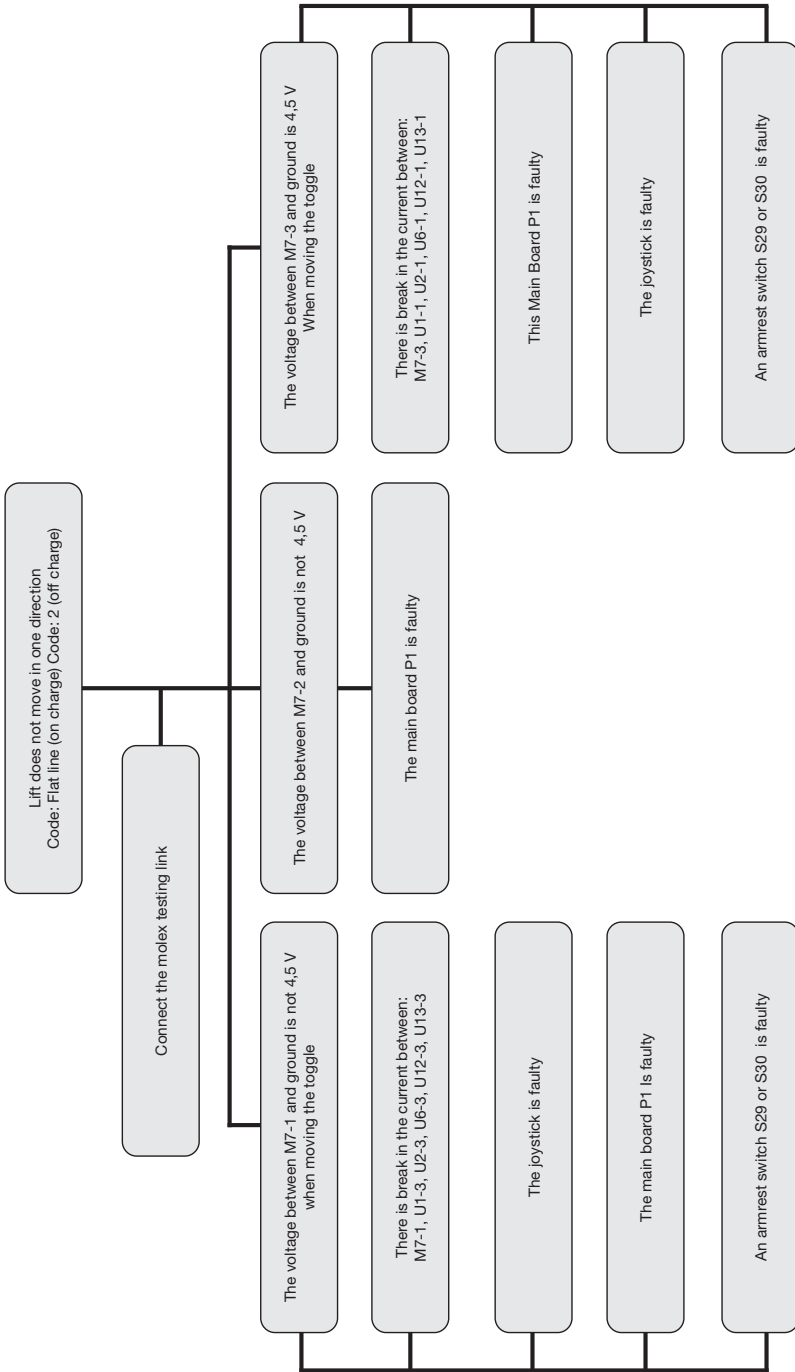

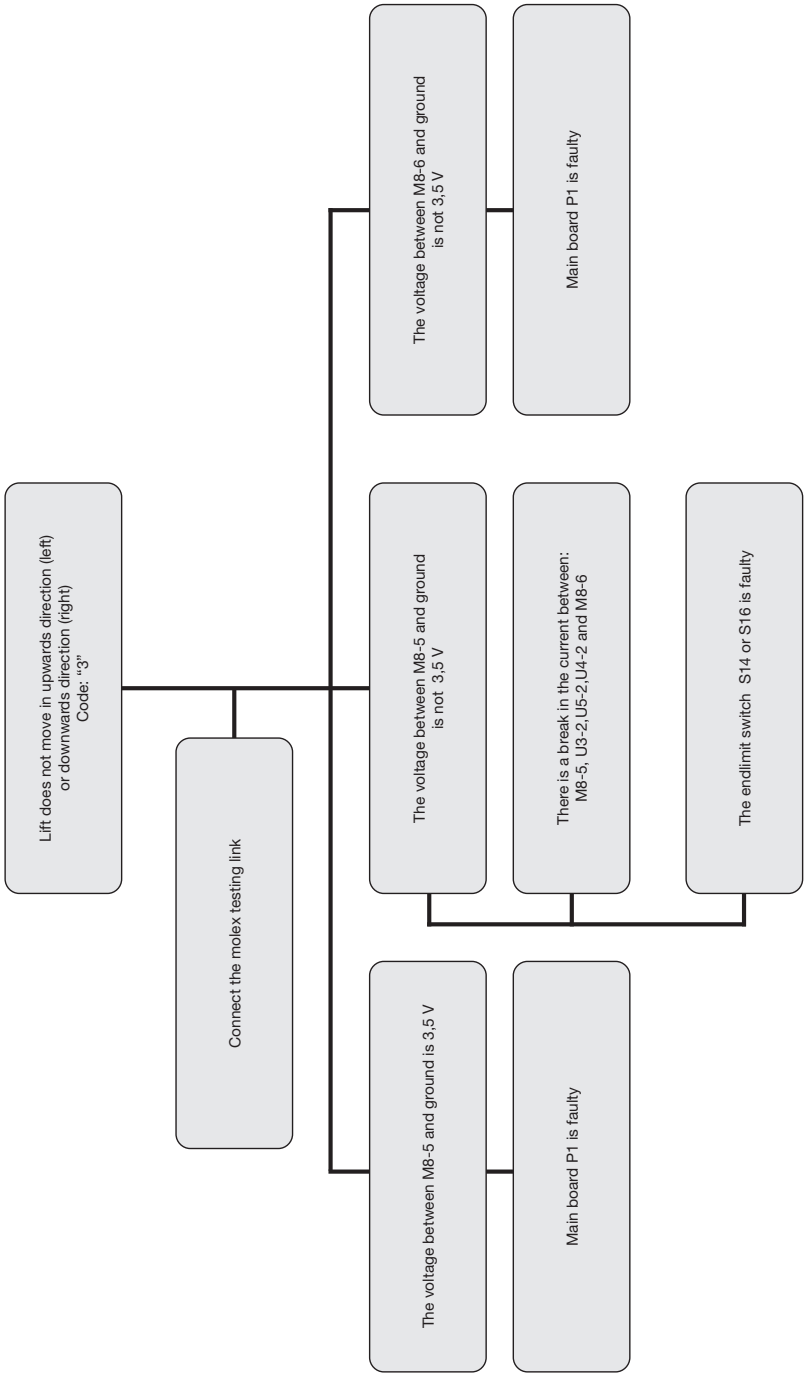

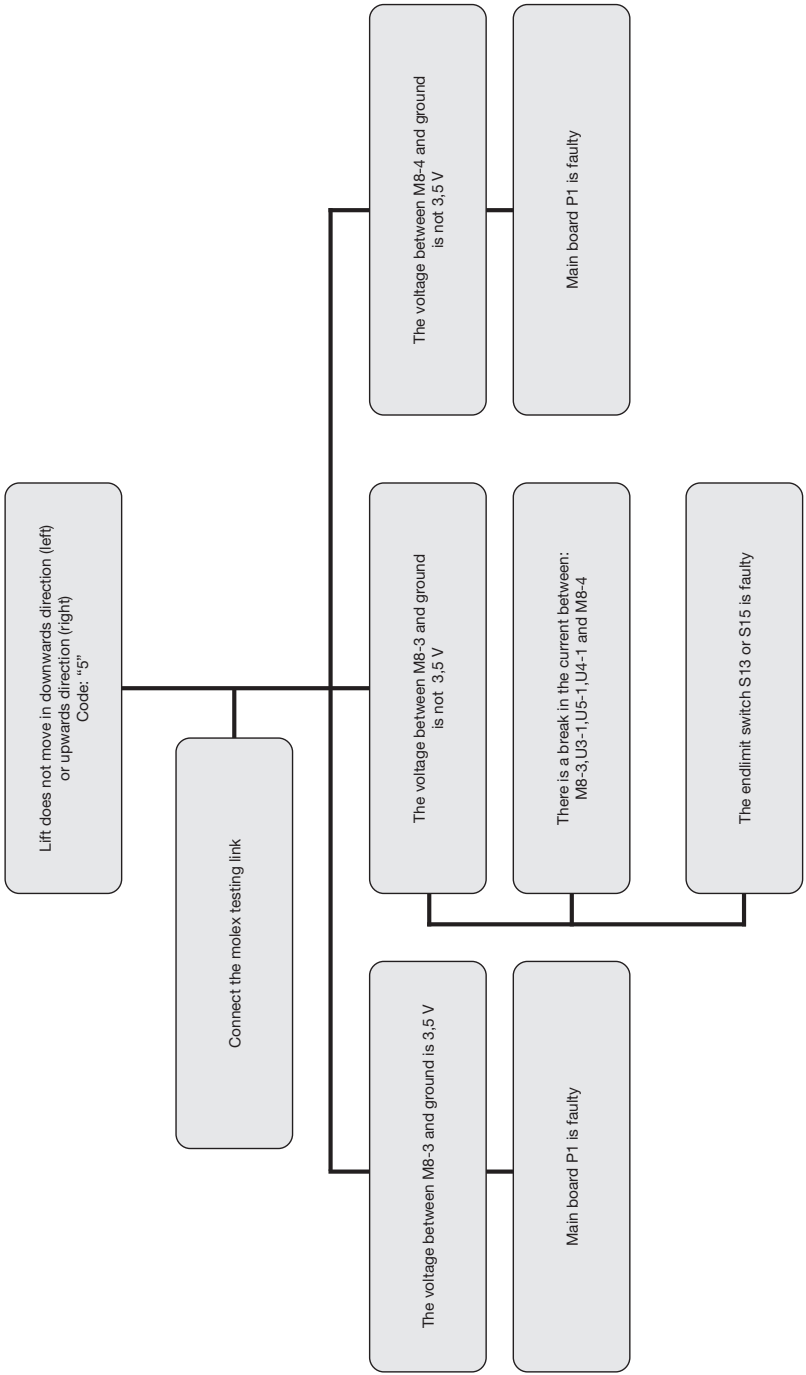

Lift does not move in downwards direction (right) or upwards direction (left)
Code: ".4"

Connect the molex testing link

The rail is on the left side of the stairs.
The lift will not move up.
The voltage between M7-5 and ground is not 3.5 V

There is an obstacle blocking the upperside of the pack or the upperside of the footrest

There is a break in the current in the line: M7-5, U9-4, U9-5, M7-7

The footrest switch S8 is faulty

The rail is on the left side of the stairs. The lift will not move up.
The voltage between M7-5 and ground is 3.5 V

Main board P1 is faulty

The rail is on the right side of the stairs. The lift will not move down.
The voltage between M7-5 and ground is 3.5 V

Main board P1 is faulty

The rail is on the right side of the stairs. The lift will not move down.
The voltage between M7-5 and ground is not 3.5V

There is an obstacle blocking the downside of the pack or the downside of the footrest

There is a break in the current in the line: M7-5, U9-2, U9-1, U9-4, U9-5 and M7-7

The front chassis edge switch S11 or S12 is faulty

The footrest switch S8, S9 is faulty

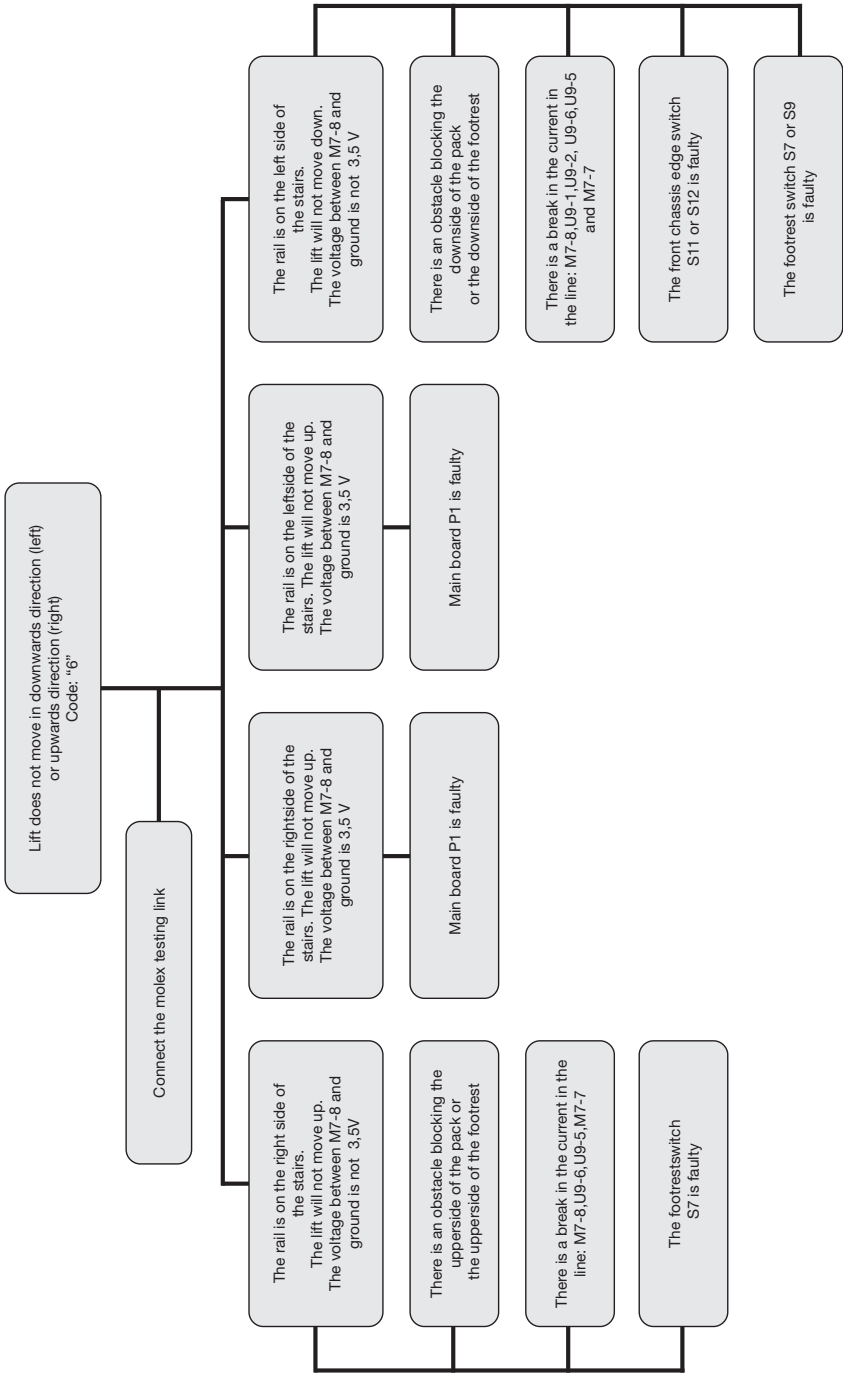

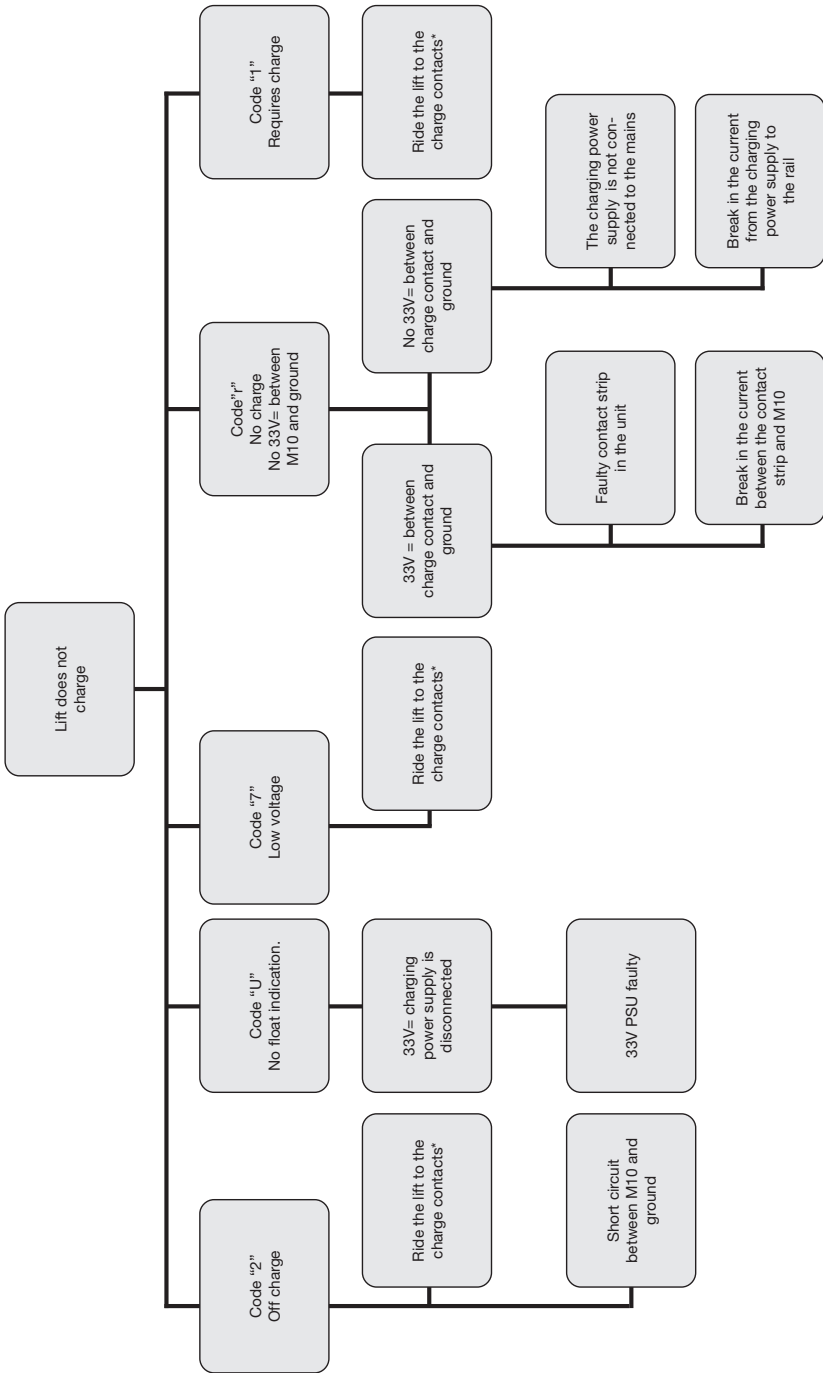

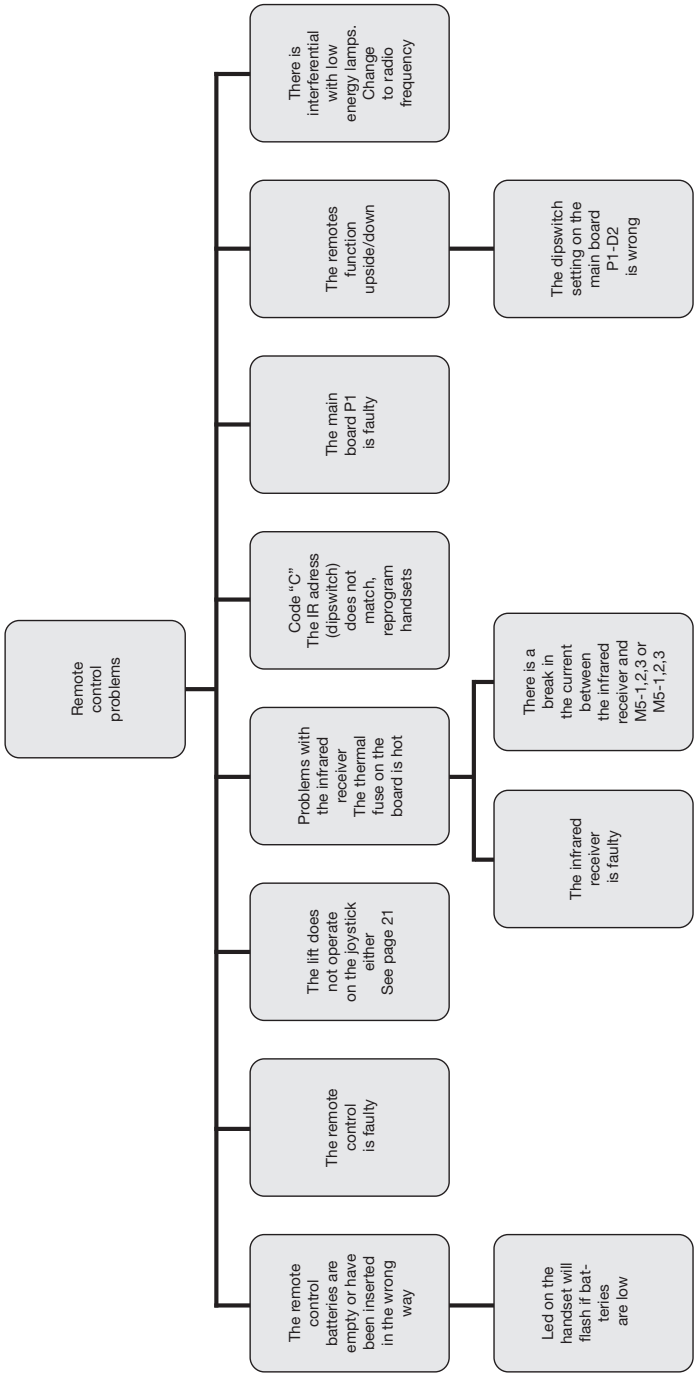

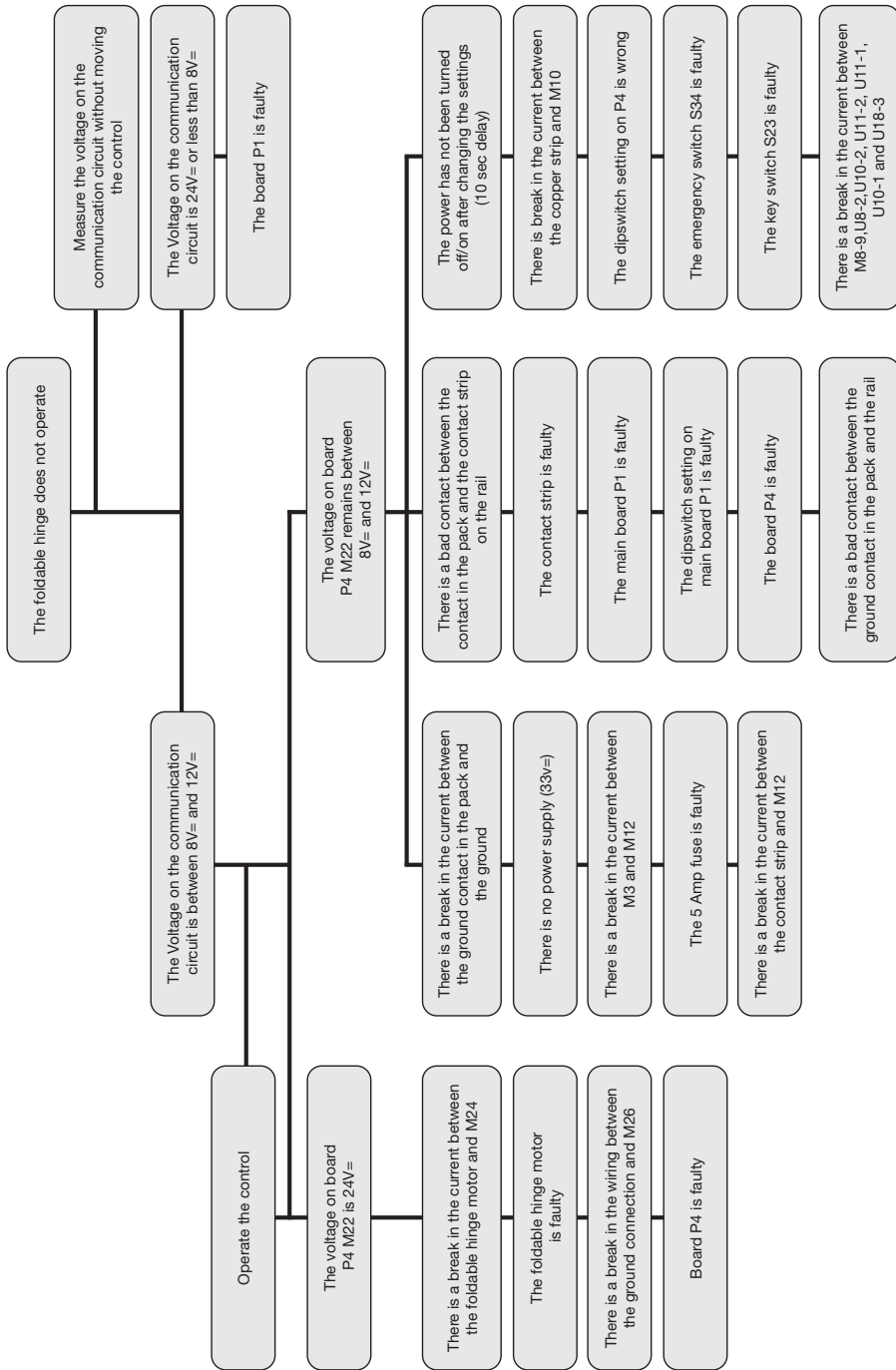

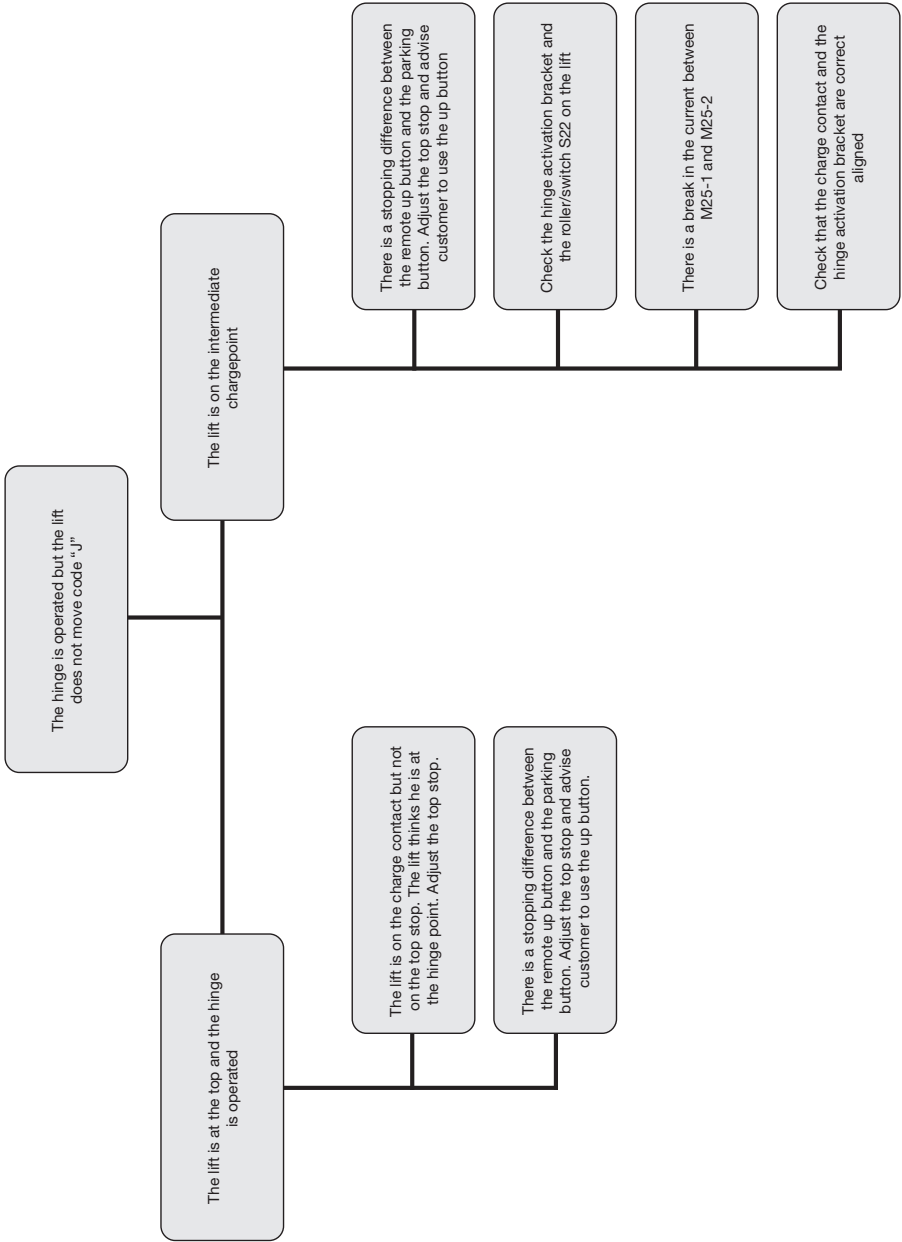

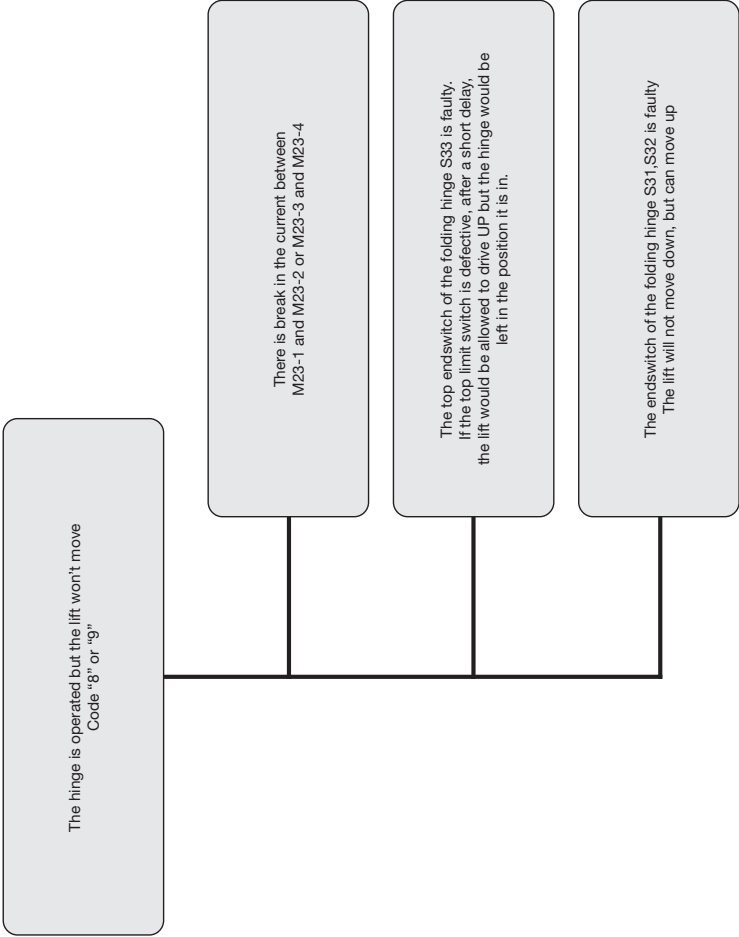

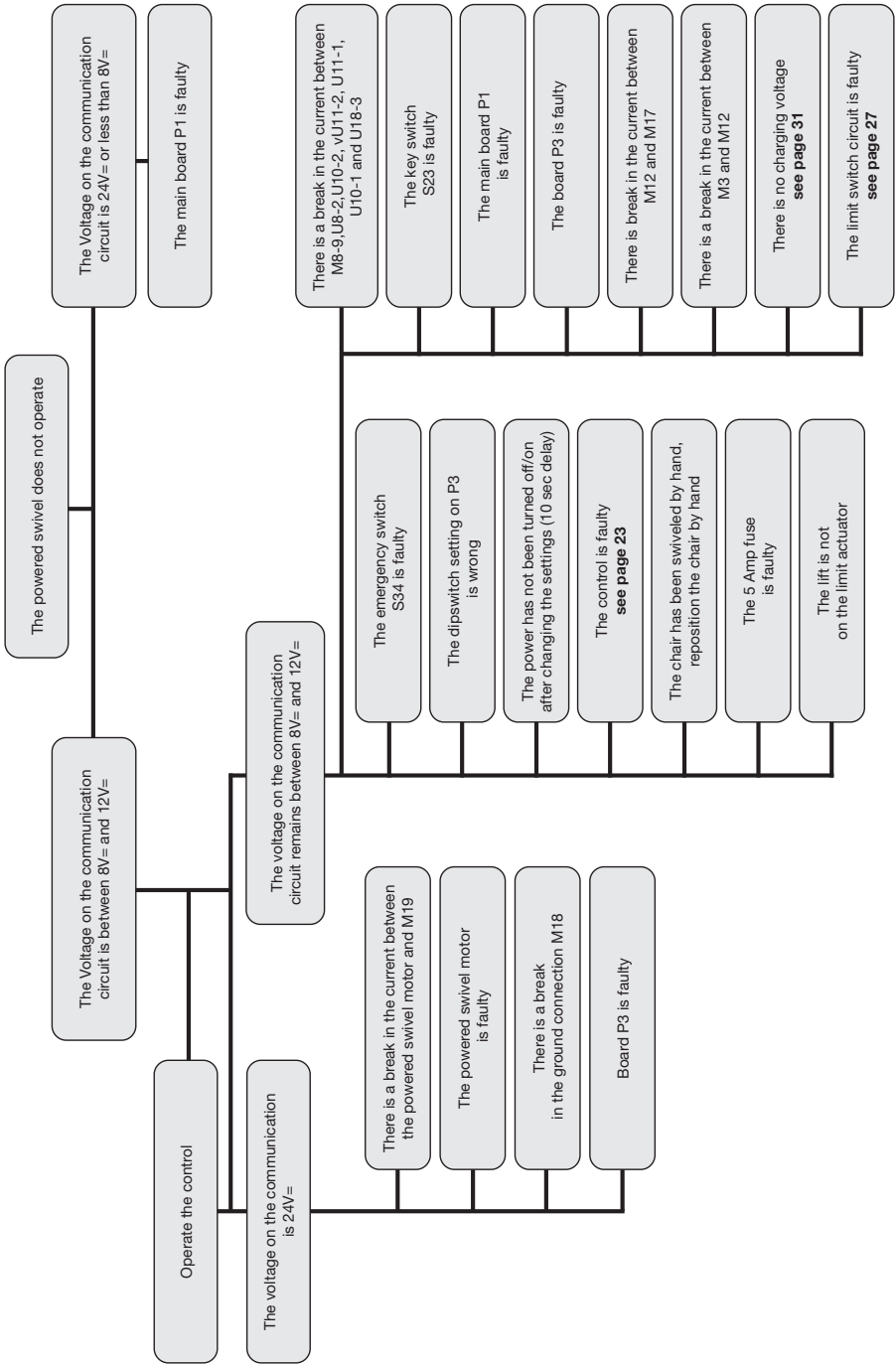

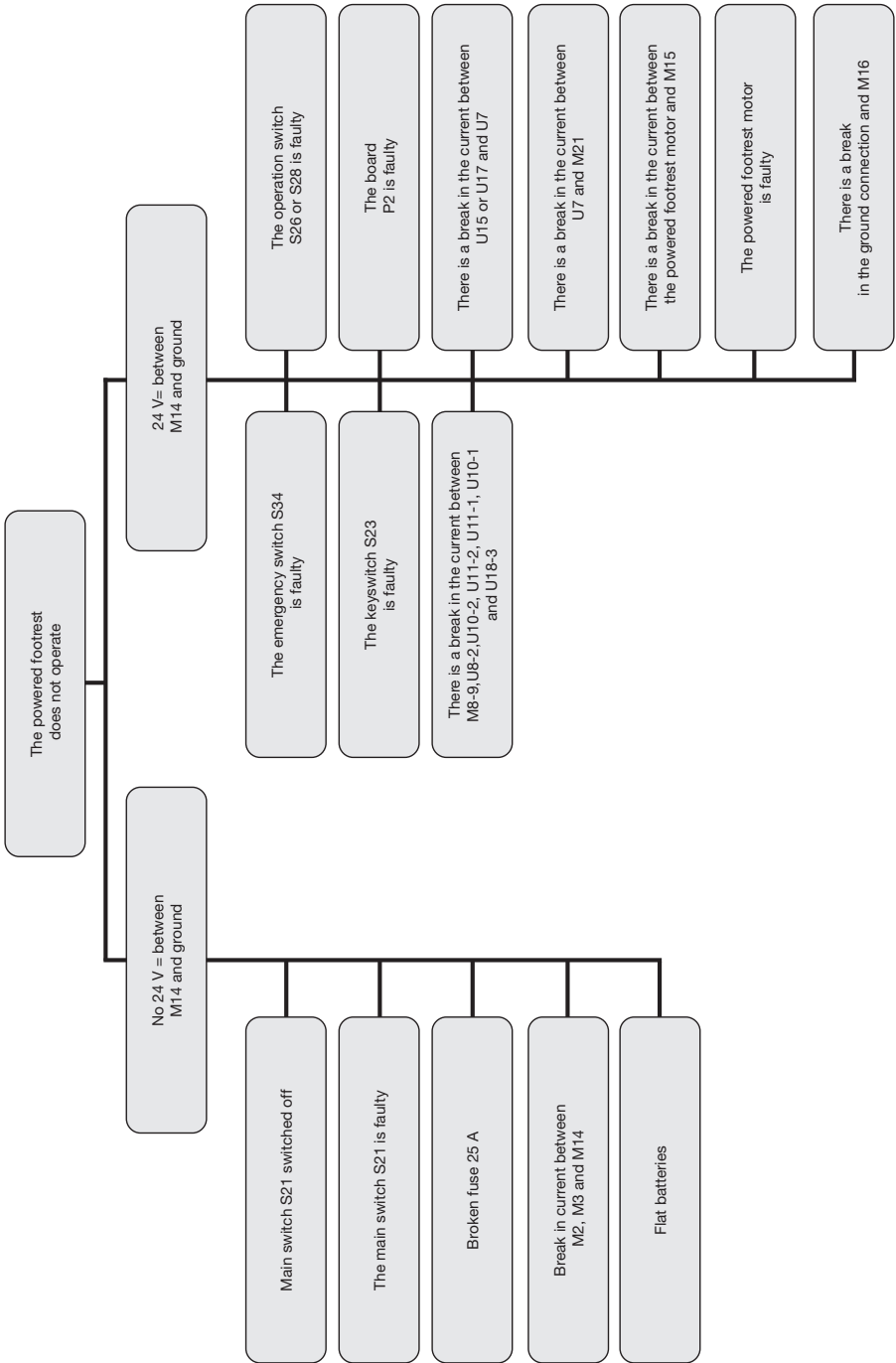

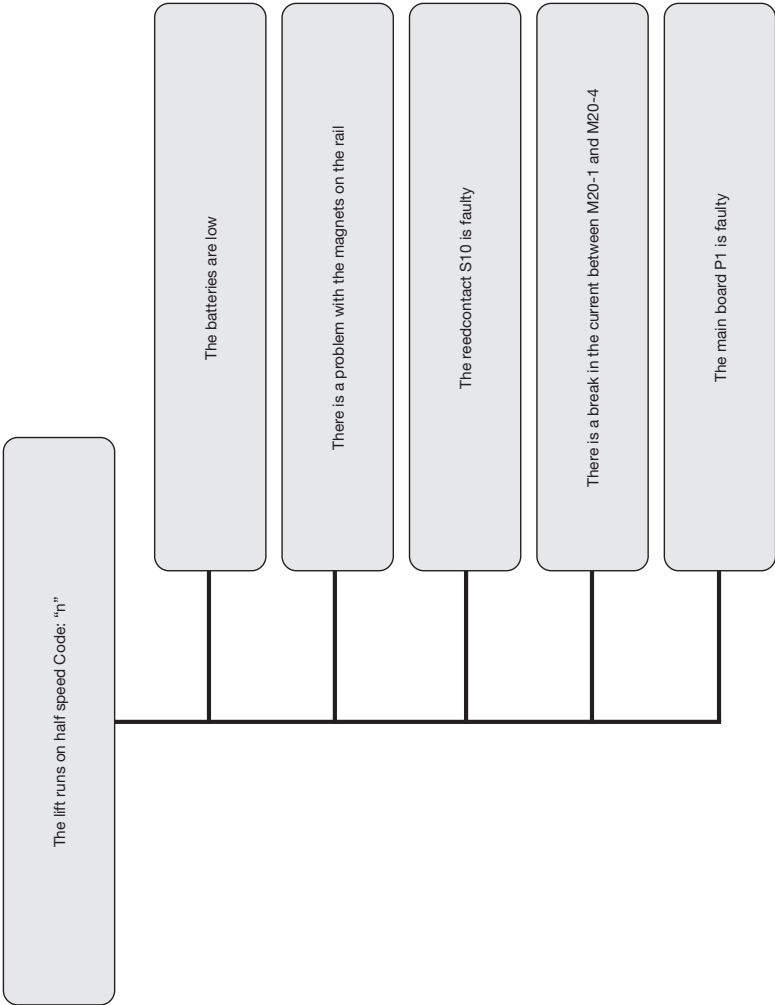



handicare

Handicare Stairlifts B.V

Newtonstraat 35
1704 SB Heerhugowaard
The Netherlands
T +31 (0)72 576 88 88
F +31 (0)72 574 34 35
stairlifts@handicare.com
www.handicare.com

Handicare Accessibility Ltd

82 First Avenue, Pensnett Estate
Kingswinford, West Midlands
DY6 7FJ United Kingdom
T. +44 (0)1384 408700
F. +44 (0)1384 408719
E. enquiries@handicare.co.uk

Handicare

2201 Hangar Place
Suite 200
Allentown, PA 18109
United States of America
Toll free: (866) 276-5438
Local: (610) 266-5260
Fax: (610) 266-5266
info@handicareusa.com

Handicare Monte-escaliers

ZI de la Croix Blanche
20 Avenue Scotté
91700 Ste Genevieve des Bois
France
Tl. : +33 (0)1.69.46.86.10
Fax : +33 (0)1.69.46.86.19
monteescaliers@handicare.fr

Handicare GmbH

Hausberger Straße 16
32457 Porta Westfalica
Deutschland
Tel: +49 (0) 571 973398-55
Fax: +49 (0) 571 973398-56
data@handicare.com